

NEWTON'S SECOND LAW

(L-6)

PROCEDURE--DATA

Note: There is a very powerful approach associated with doing Newton Second Law problems. It is important that you become familiar with and trusting in that protocol. This lab will hopefully help you do that.

Part A: (cookbook--a double Atwood Machine)

a.) First, connect the Smart Pulley to your Lab Pro's DIG SONIC 1 input. Open the Logger Pro program titled *Velocity vs Time* graph (on your desktop).

b.) An *Atwood Machine* is made up of two unequal masses connected by a string hung over a pulley. A *Double Atwood Machine* is an *Atwood Machine* that incorporates two pulleys within the system. This lab is designed to allow you to deal with *Newton's Second Law* via a *Double Atwood Machine*.

c.) Look at the sketch of the Double Atwood Machine.

--**Notice** that the mass m_2 is the *total mass wrapped up in the free-hanging pulley AND the hanging weight attached to that pulley* (that is why there is a dotted line around both in the sketch).

--**Notice** that m_2 should initially be positioned about *4 inches* below the bottom of the pulley's support rod (this is to insure that the line of the tension force in each string is at least close to vertical).

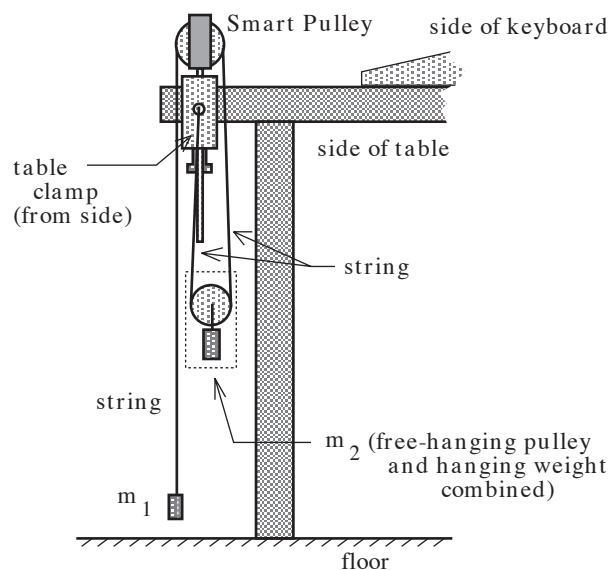

--**Notice** that m_2 travels half the distance mass m_1 travels in the same amount of time (this means m_1 and m_2 don't accelerate at the same rate--what do you suppose the relationship is between the two?).

Having made these observations, construct the Double Atwood Machine as shown in the sketch.

c.) Attach a 100 grams to the pulley and mass the whole assembly (i.e., both the 100 grams AND the pulley). Call this m_2 . With a 50 gram mass for m_1 , use the computer's *velocity versus time* graph to determine the magnitude of the *acceleration* of mass m_1 after release. (Do this by having the computer generate a best fit line, then by looking at that line's slope—that slope will be the average *change of velocity over time* for the line, or the acceleration of the cart.)

d.) Repeat *Part c* using 120 grams (plus pulley) instead of 100 grams plus.

CALCULATIONS

Part A: (double Atwood Machine)

1.) Use Newton's Second Law to derive a *general algebraic expression* for the theoretical acceleration a_1 of m_1 . Be complete and show all f.b.d.'s, etc. (be careful--your result should have some "4's" and "2's" in it--if it doesn't and you're confused, come see me!).

Note: The phrase "a general algebraic expression" means just that--an expression made up solely of algebraic terms that has the acceleration a on the left-hand side of the *equal sign* and all constants and other variables on the right-hand side of the *equal sign*. Never put numbers in for the variables--that comes later.

2.) Use the expression derived in Calculation #1 to determine a value for the *theoretical acceleration* of your DOUBLE ATWOOD MACHINE when the 100 gram mass was attached to the pulley (DON'T MIX UNITS--you are working in the MKS units system--that means all masses must be in *kilograms* and distances in *meters*).

3.) During lab, you used the computer to generate an *experimentally determined value* for the *acceleration* of m_1 . Do a % comparison between that *experimental acceleration* and the *theoretical acceleration* you just calculated. Comment.

4.) For the 120 gram mass (plus pulley), execute *Calculation 2*.

5.) For the 120 gram mass (plus pulley), execute *Calculation 3*.

6.) Which of the % deviations came out better, the one done in *Calculation 3* or the one done in *Calculation 5*. Comment briefly (very briefly-- look at the *Question* below!).

QUESTION:

I.) Although it may not have turned out this way, why *might* you expect the result from *Calculation 3* to be better than the result from *Calculation 5*? That is, what physical, error-producing characteristic would you expect to be more pronounced in the 120 gram set-up, versus the 100 gram set-up? (This is not supposed to be hard. Think about what is physically going on with the set-ups and what might make the experimental deviate from the theoretical.)

